

01

## Perchè la Vosper?

Dopo la PT-596 americana, l'imponente Schnellboot S-100 della Kriegsmarine tedesca ed il MAS della Regia Marina italiana, la britannica Vosper della Royal Navy completa la serie in scala 1:35 delle più note e famose motosiluranti della Seconda Guerra Mondiale. Come per i precedenti kit in scala 1:35 le grandi dimensioni consentono di esaltare la cura dei dettagli. In particolare grande cura ed attenzione è stata dedicata nella realizzazione del ponte, dell'armamento offensivo, costituito dai tubi lanciasiluri, dell'armamento difensivo e delle sovrastrutture.

## Why Vosper?

*After the American PT-596, the huge, in terms of size, German Kriegsmarine Schnellboot S-100 and the Italian MAS, the British Royal Navy Vosper completes the series of the most popular and famous torpedo boats in 1:35 scale of World War II. Thanks to the large scale, it's possible to bring out a great care and attention to small details. In particular, great care and attention has been devoted to the construction of the bridge, the offensive armament, consisting of the torpedo tubes, and the defensive armament such as the Vickers turret.*

02



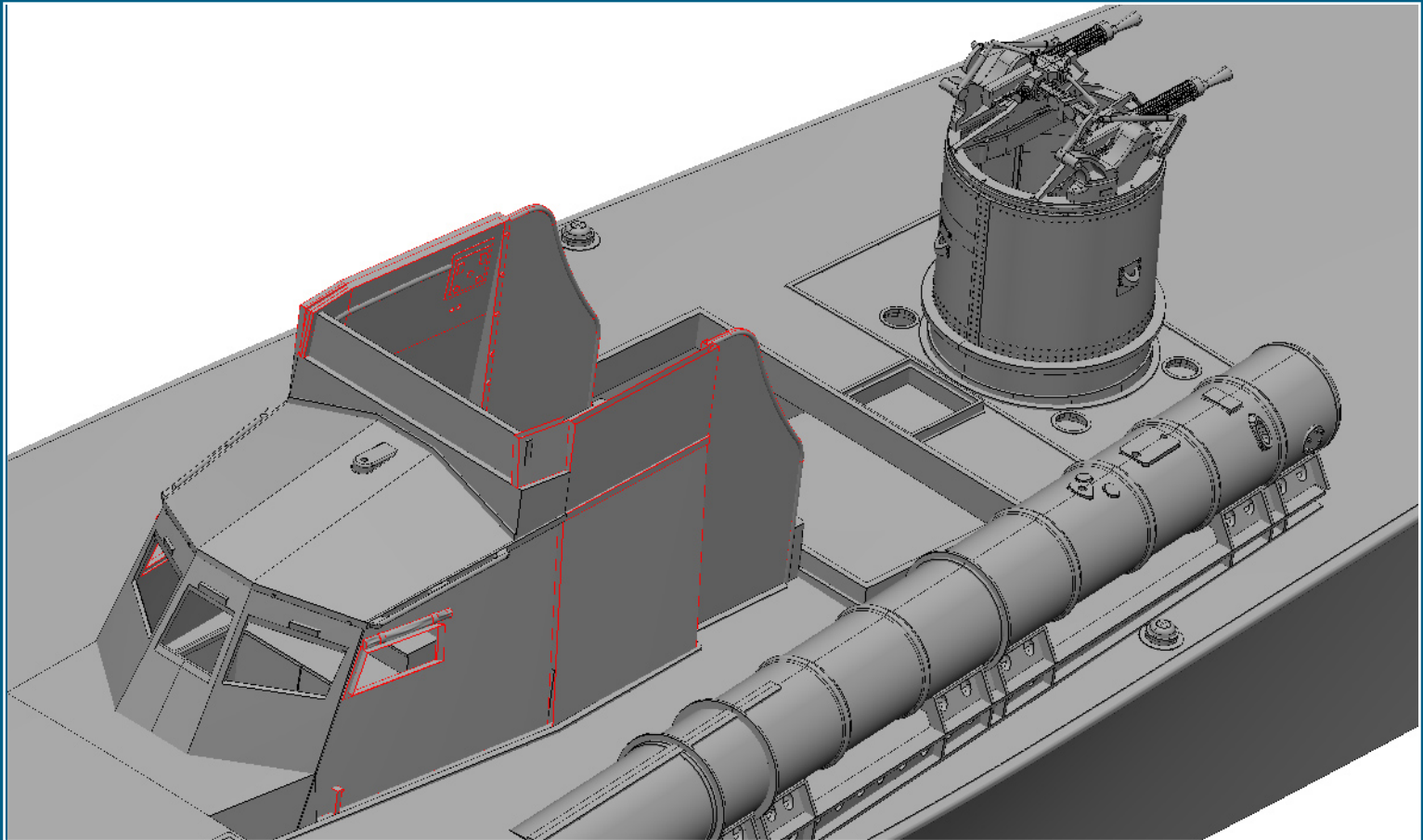

03

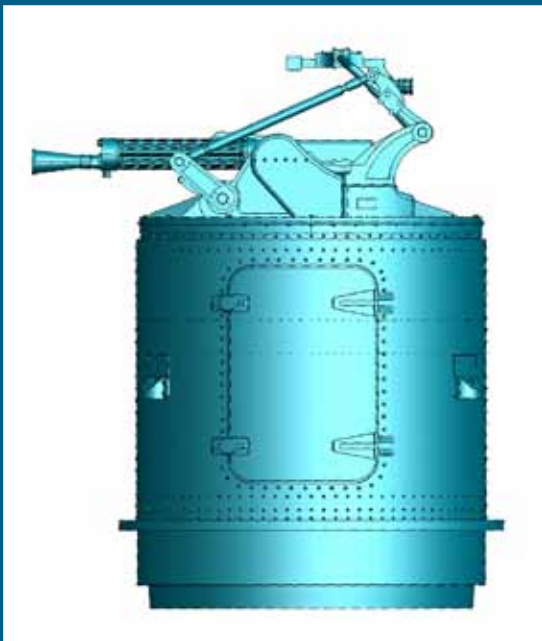

04

01/02:  
Profilo/Side view

03:  
Pilotina e tubi lanciasiluri  
Torpedo tubes  
and wheelhouse

04/05:  
Torretta Vickers  
Vickers turret

05

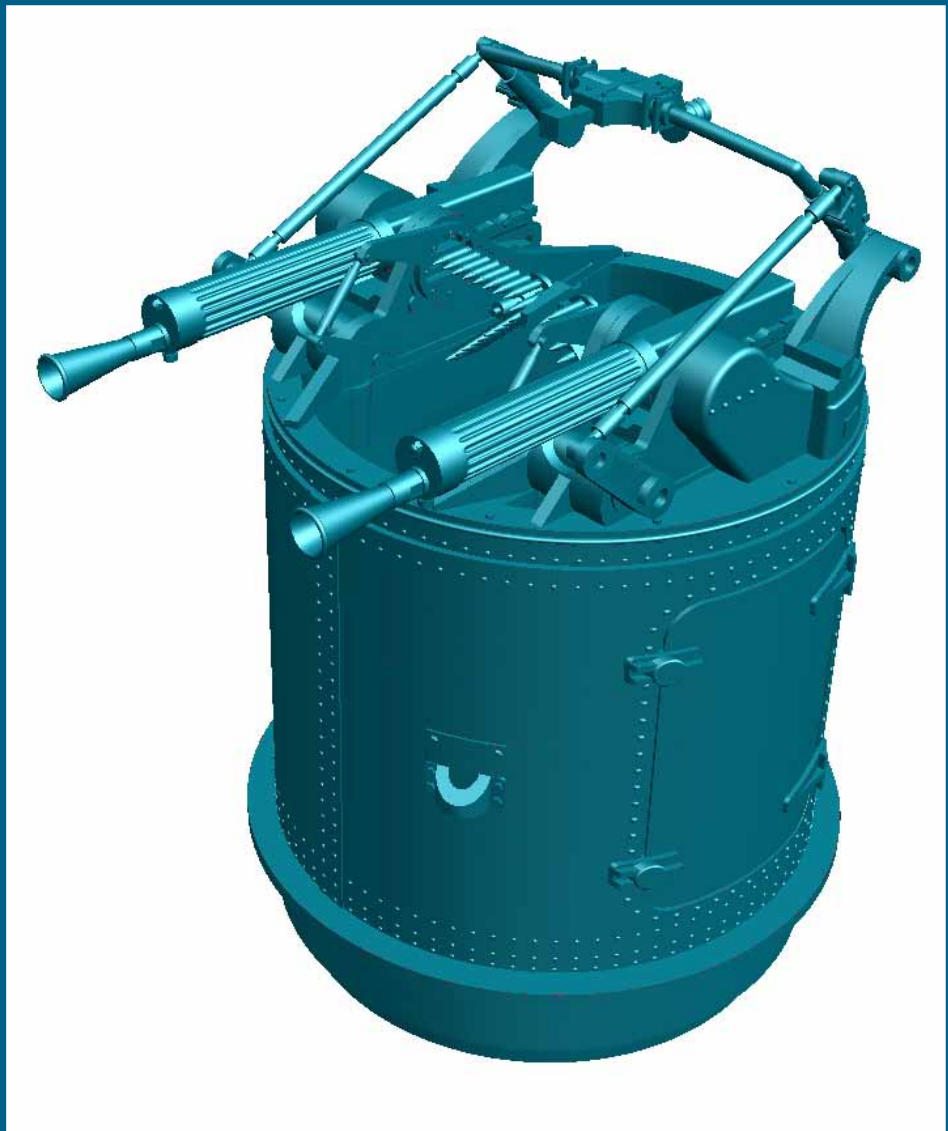

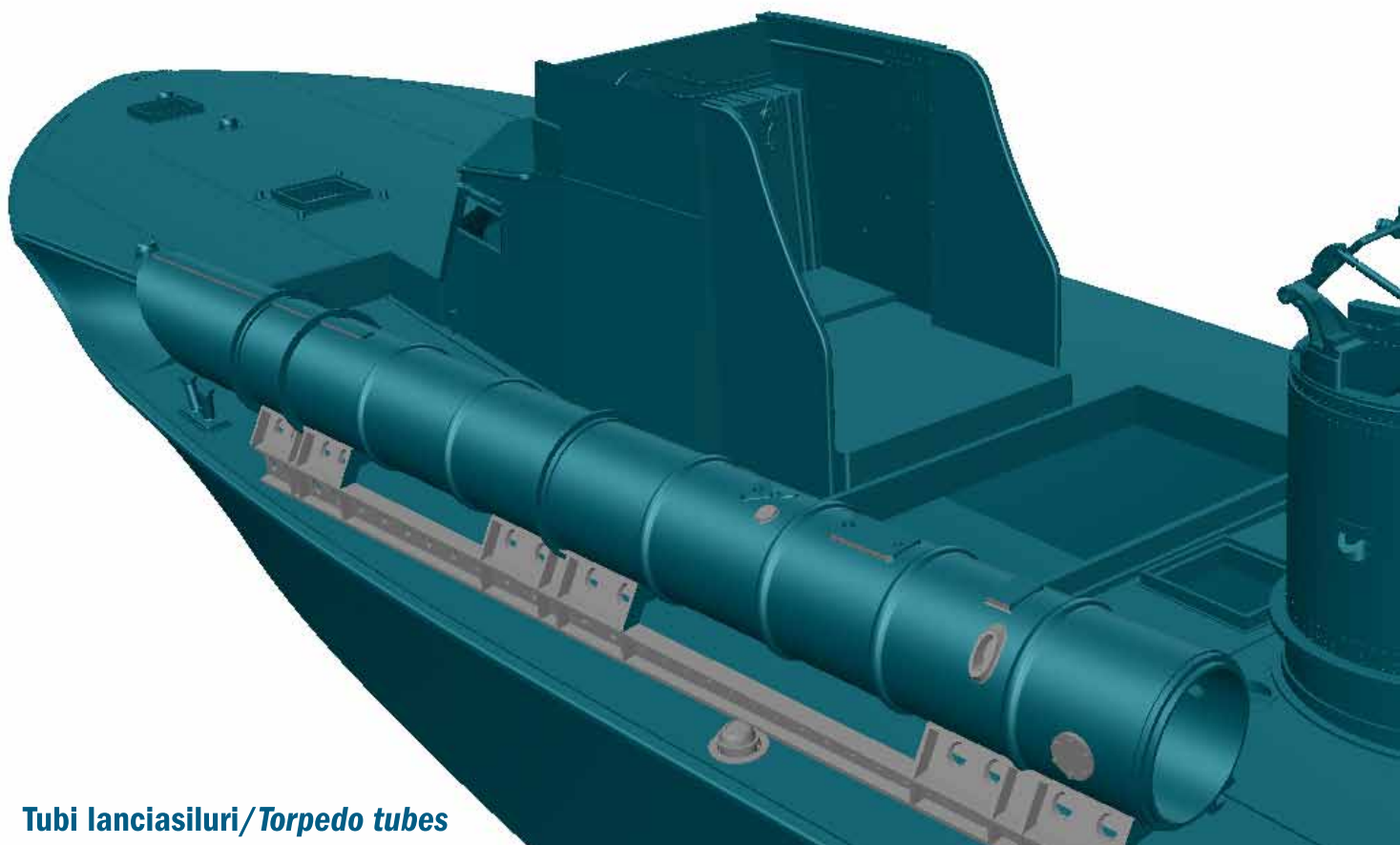

**Tubi lanciasiluri/Torpedo tubes**

## Vosper, cenni storici

L'azienda Vosper divenne famosa durante la Seconda Guerra Mondiale per la produzione delle piccole e veloci Motor Torpedo Boats (MTB) e delle Motor Gun Boats (MGB) per la Royal Navy. Tra i diversi mezzi in produzione, le MTB Vosper 72"6' si caratterizzavano per una significativa vita operativa connotata da diversi profili di missione come il pattugliamento costiero ed il supporto anti-sommergibile nel mare del Nord e nel Canale della Manica. Mosse da 3 motori da 4.200 hp erano in grado di raggiungere una velocità prossima ai 40 nodi (oltre 70 km/h). Le prime versioni furono introdotte all'inizio della Guerra ma progressivamente vennero introdotte nuove varianti, type I e type II, che si caratterizzavano per una diversa combinazione di armamento offensivo e difensivo. Generalmente erano armate con tubi lanciasiluri da 457 mm., cariche di profondità e mitragliere Vickers 0.303 o, più raramente, da 0.5 per la difesa antiaerea. L'equipaggio era costituito da 10 a 13 uomini.

## Vosper, historical highlights

*Vosper company became famous, during the Second World War, for the production of small and fast Motor Torpedo Boats (MTB) and Motor Gun Boats (MGB) for the Royal Navy. Among the various boats in production, the Vosper MTB 72 "6' were characterized by a significant life cycle with different mission profiles as the coastal patrol and the anti-submarine support in the North Sea and English Channel. Moves from 3 engines with an impressive power of 4,200 hp, Vosper MTB was able to reach a speed close to 40 knots (70 km / h). The first versions were introduced at the beginning of the war but were gradually introduced new variants, type I and type II, which were characterized by a different combination of offensive and defensive weaponry. They were usually armed with 457 mm torpedo tubes., depth charges, and 0.303 Vickers machine guns or, more rarely, from 0.5 Vickers machine guns , for air defense. The crew consisted of 10 to 13 men.*

# 5610 Vosper

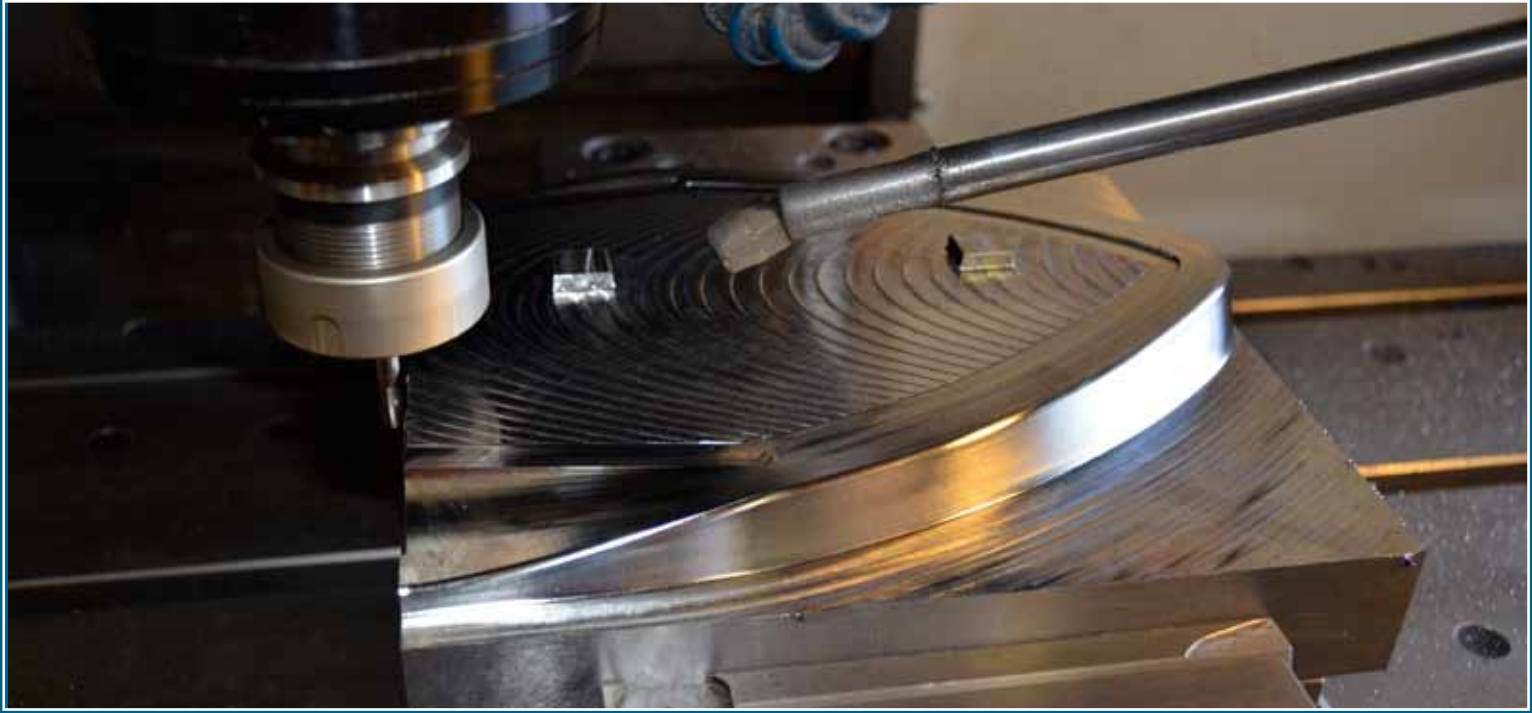

01

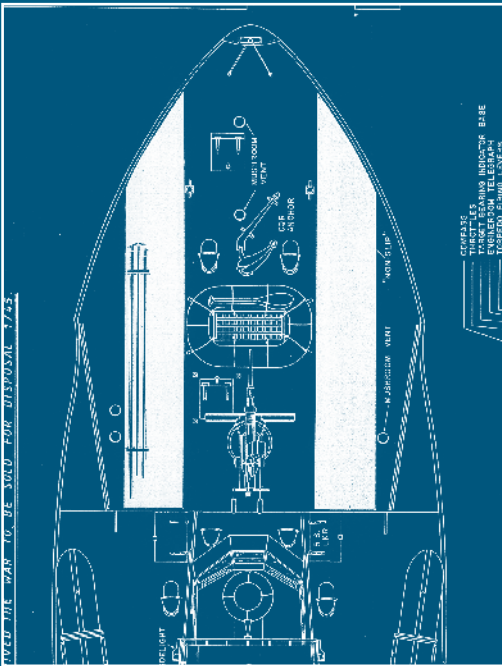

02

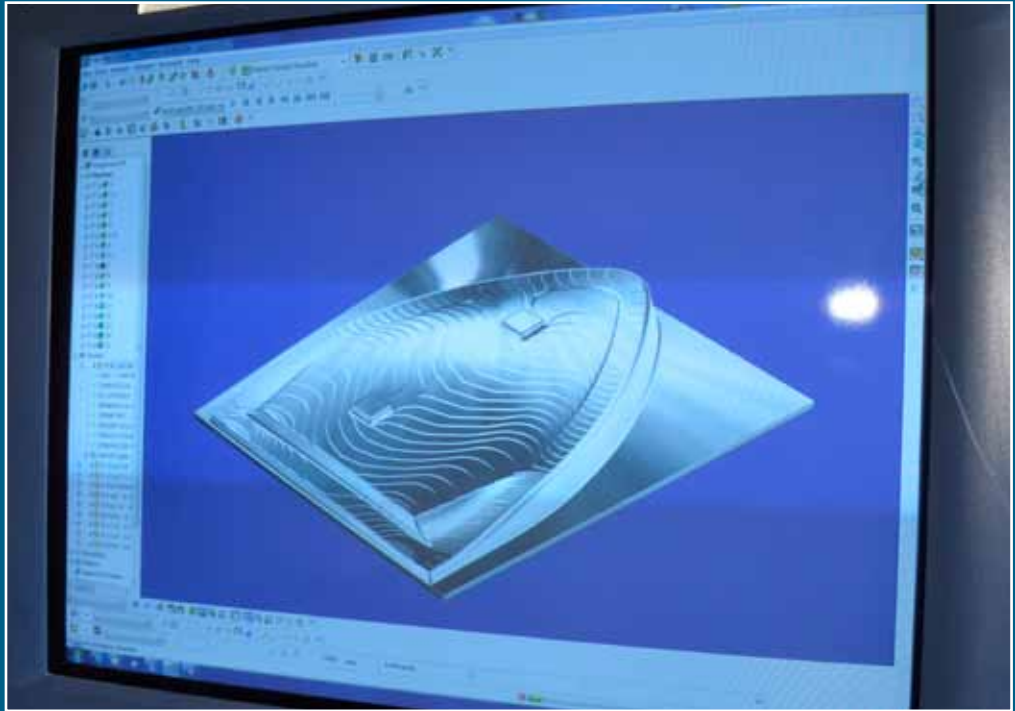

03

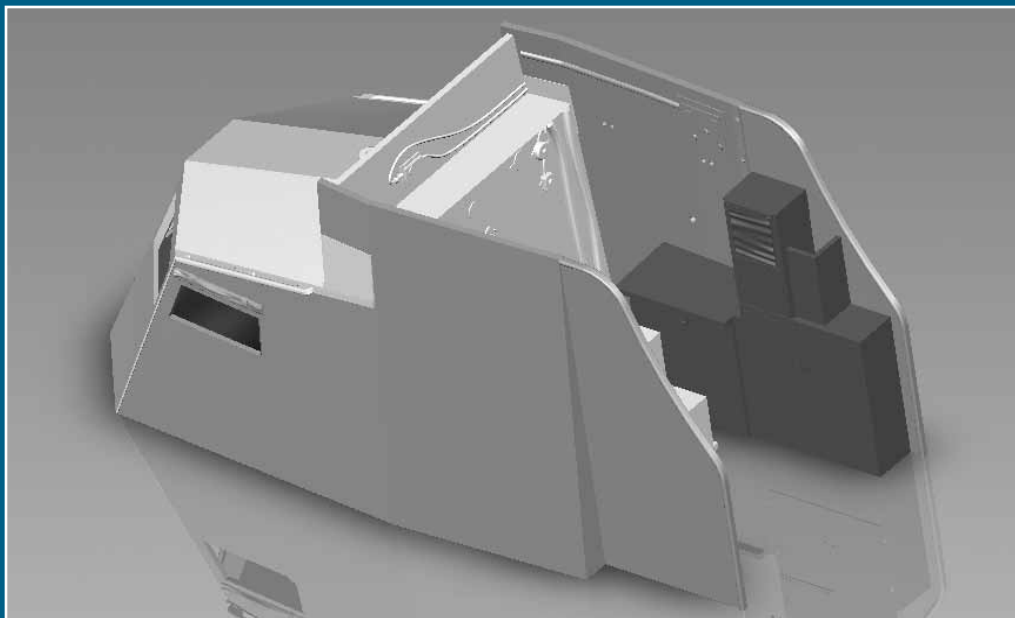

01/02:  
Prua/Bow

03:  
Pilotina  
wheelhouse